

# Base Cabinet 2 Doors, 1 Drawer

## Step-by-Step Assembly Instructions

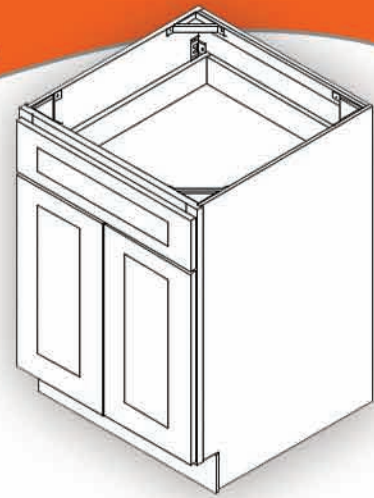

Code	Item	Qty
A	R/L SIDE PANEL	2
C	DRAWER L/R SIDE PANEL	2
D	BOTTOM PANEL	1
E	DRAWER BACK PANEL	1
F	DRAWER BOTTOM PANEL	1
G	SHELF	1
H	BACK PANEL	1
J	TOE KICK PLATE	1
K	DRAWER GLIDE-CABINET	2
L	DRAWER GLIDE-DRAWER	2
M	FRONT FACE	1
N	DRAWER FRONT PANEL	1
T	REAR SLIDE BRACKET	2
U	PLASTIC SHELF CLIPS	4

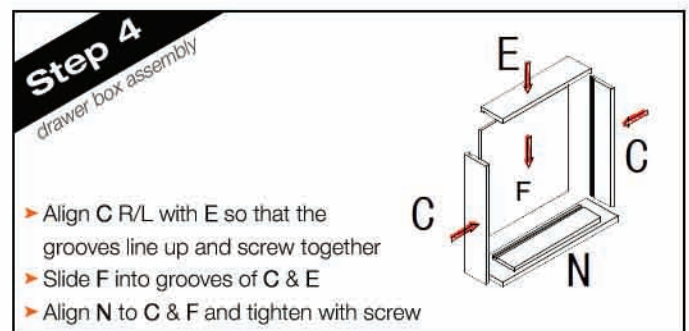
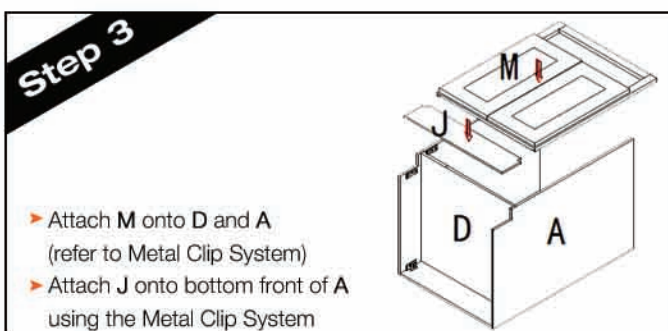
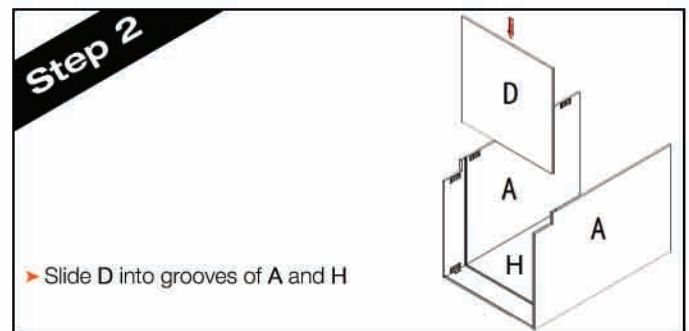
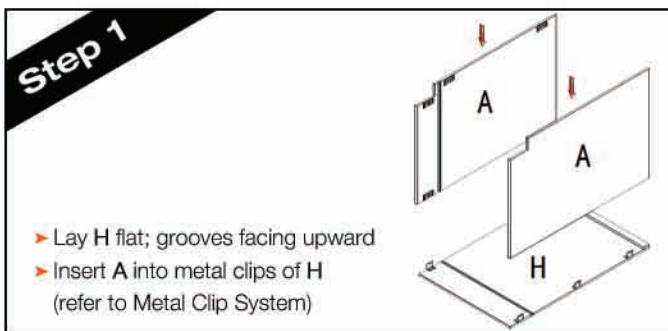
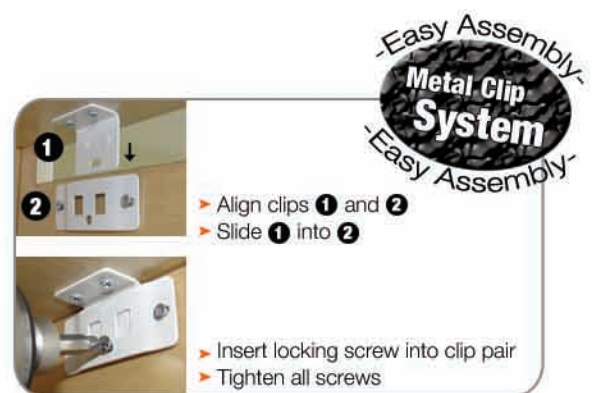

Flip this page for steps 5-8 →

# Base Cabinet 2 Doors, 1 Drawer

## Step-by-Step Assembly Instructions

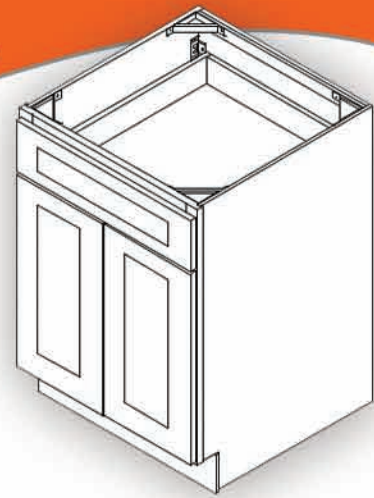

Code	Item	Qty
A	R/L SIDE PANEL	2
C	DRAWER L/R SIDE PANEL	2
D	BOTTOM PANEL	1
E	DRAWER BACK PANEL	1
F	DRAWER BOTTOM PANEL	1
G	SHELF	1
H	BACK PANEL	1
J	TOE KICK PLATE	1
K	DRAWER GLIDE-CABINET	2
L	DRAWER GLIDE-DRAWER	2
M	FRONT FACE	1
N	DRAWER FRONT PANEL	1
T	REAR SLIDE BRACKET	2
U	PLASTIC SHELF CLIPS	4

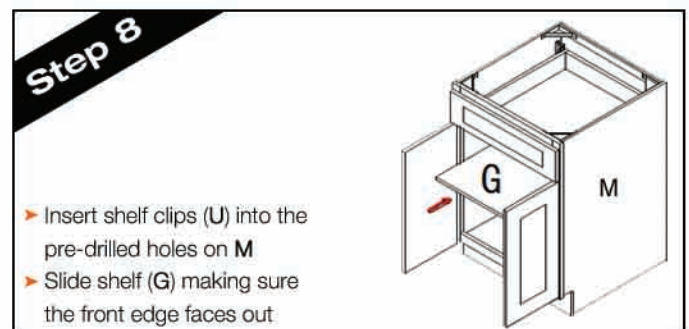
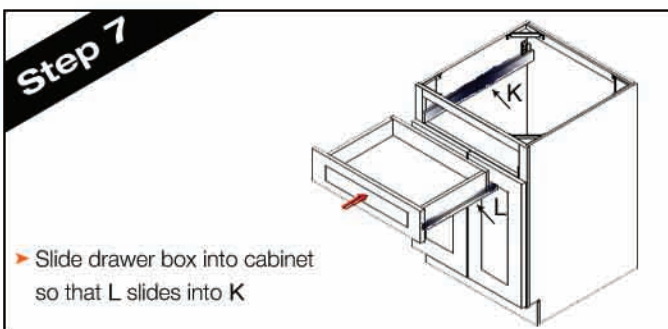
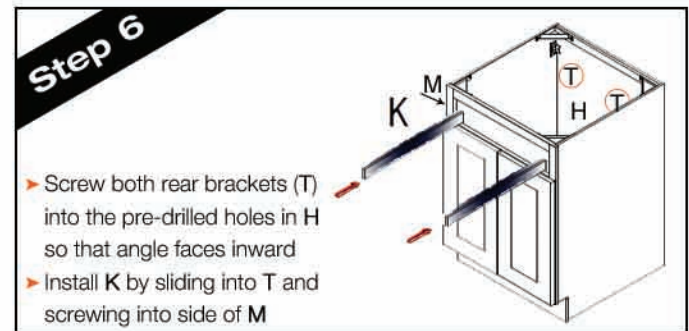
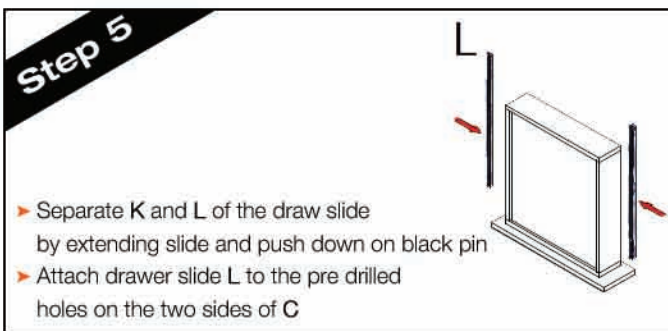

Flip this page for steps 1-4 →