

Vanity with 4-6 Drawers

Step-by-Step Assembly Instructions

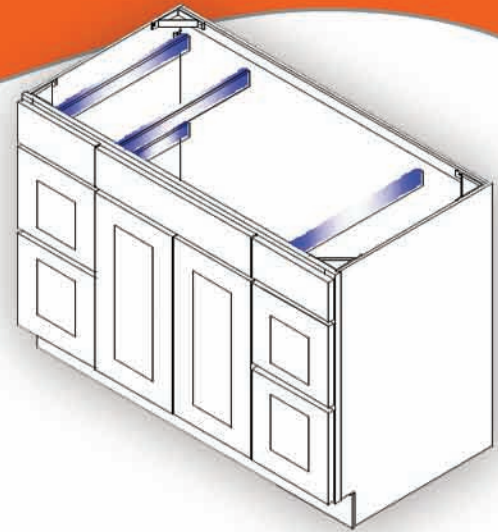

Code	Item	Qty
A	R/L SIDE PANEL	2
C	DRAWER L/R SIDE PANEL	12
D	BOTTOM PANEL	1
E	DRAWER BACK PANEL	6
F	DRAWER BOTTOM PANEL	6
H	BACK PANEL	1
J	TOE KICK PLATE	1
K	DRAWER GLIDE - CABINET	12
L	DRAWER GLIDE - DRAWER	12
M	FRONT FACE	1
N	DRAWER FRONT PANEL	6
T	REAR SLIDE BRACKET	12

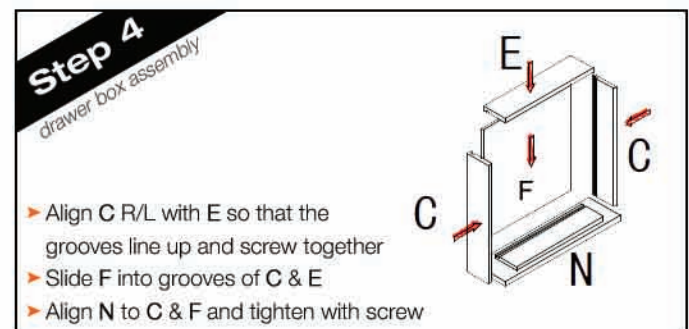
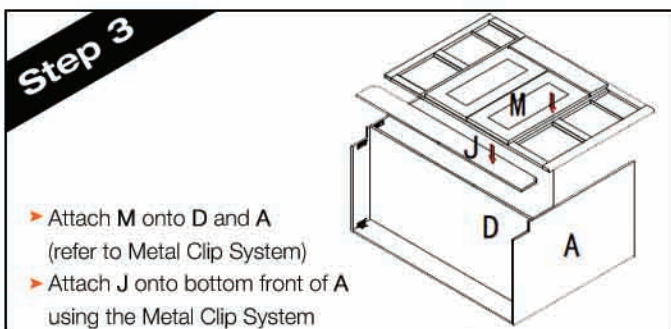
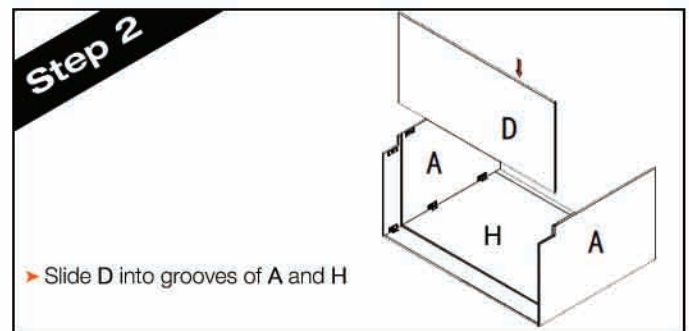
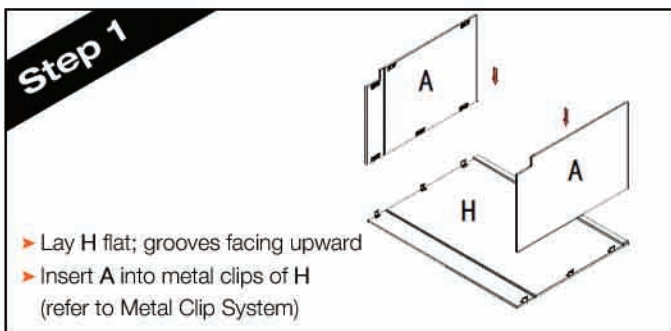
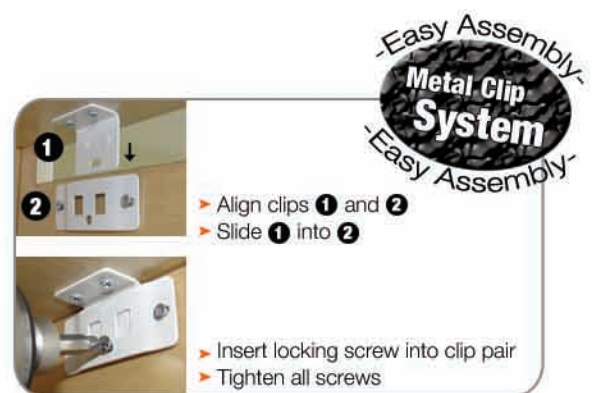

Flip this page for steps 5-7 →

Vanity with 4-6 Drawers

Step-by-Step Assembly Instructions

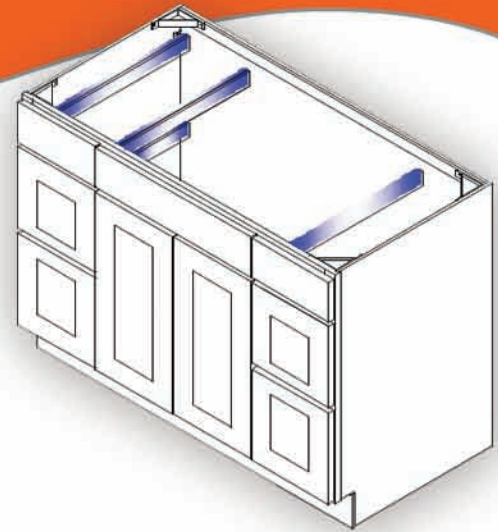

Code	Item	Qty
A	R/L SIDE PANEL	2
C	DRAWER L/R SIDE PANEL	12
D	BOTTOM PANEL	1
E	DRAWER BACK PANEL	6
F	DRAWER BOTTOM PANEL	6
H	BACK PANEL	1
J	TOE KICK PLATE	1
K	DRAWER GLIDE - CABINET	12
L	DRAWER GLIDE - DRAWER	12
M	FRONT FACE	1
N	DRAWER FRONT PANEL	6
T	REAR SLIDE BRACKET	12

-Easy Assembly-
Metal Clip System
-Easy Assembly-



- ▶ Align clips **1** and **2**
- ▶ Slide **1** into **2**

- ▶ Insert locking screw into clip pair
- ▶ Tighten all screws

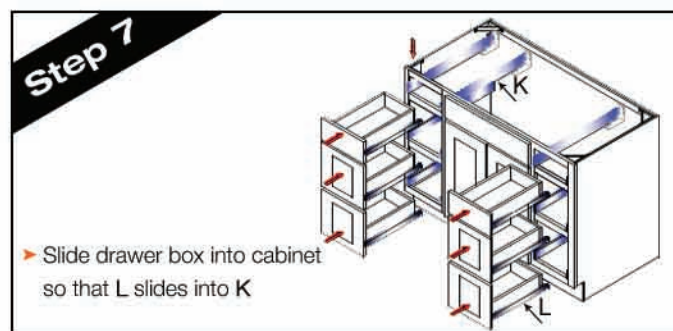
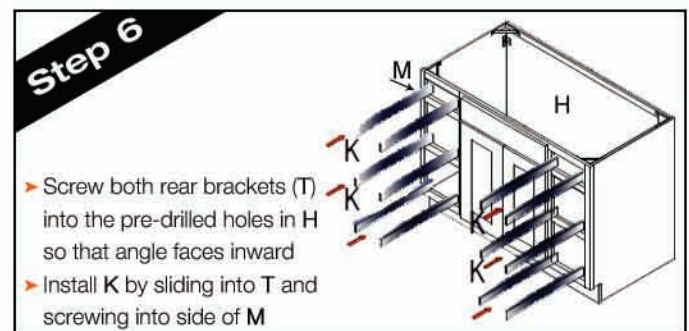
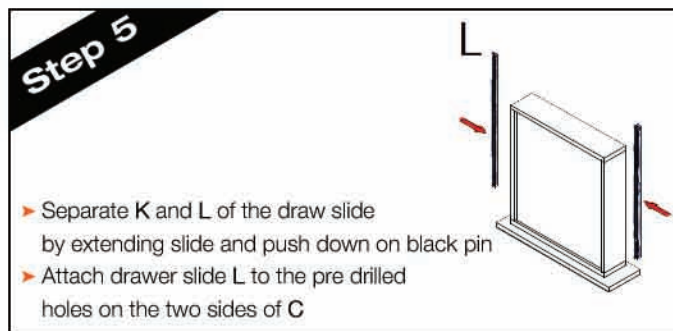

Flip this page for steps 1-4 →